

# Reconfigurable Optical Backbone Network Architecture for Indoor Wireless Communication

K.A. Mekonnen, E. Tangdiongga, A.M.J. Koonen

COBRA Research Institute, Eindhoven University of Technology, Eindhoven, The Netherlands  
k.a.mekonnen@tue.nl

*Indoor fiber-wireless networks have to be designed in such a way that the backbone architecture is highly dynamic and future-proof. A communication network employing both optical and advanced radio systems allows us to combine the best features of both systems. We present a hybrid and re-configurable in-building network architecture design that can support ultra-high data rates. Bidirectional transmission of 10 Gb/s data rate per user is demonstrated. Since the backbone network is format-transparent, a multitude of independently tailored services can be supported both in the downlink and uplink directions.*

## Introduction

The exponential rise in the number of mobile devices and the ever growing demand for bandwidth hungry services [1], require indoor wireless systems that can provide high capacity. Infrared optical wireless communication using narrow pencil beams has been shown to offer secure and ultra-high capacity wireless transmission links that can be assigned on demand [2]. Various beam steering techniques have been reported for infrared point-to-point optical wireless communication [3, 4]. Recently, a two-dimensional beam steering technique using a passive diffractive module (using gratings) has been demonstrated [5]. The beam is steered according to its wavelength making it less complex, fast, and the beam steering control can be done remotely. Utilizing the wavelength domain, a large number of users can be supported by using different beams, each at a unique wavelength. Since infrared point-to-point optical wireless communication involves line-of-sight propagation between transmitters and receivers, adequate management and control is essential to support mobility and connection reestablishment in case of shadowing. Advanced localization and tracking capabilities of millimeter wave (mm-wave) radio systems can be implemented for improved ranging and localization [6]. The 7 GHz bandwidth available in the 60 GHz range radio systems is also well-suitable for data transmission in the uplink direction. In addition, reusing the downlink optical carriers for uplink transmission allows us to reduce the required number of light sources in the network, reducing the overall cost and simplify control and management of the system.

In this paper, a bidirectional dynamic and robust in-building network architecture employing optical infrared pencil beam downstream and mm-wave radio-over-fiber (RoF) upstream communication employing carrier reuse is demonstrated. The hybrid network allows us to harvest the large bandwidth of optical communication and the advanced control and management capabilities of radio systems in indoor environments. The network is also cost-efficient, re-configurable and highly scalable as resources can be assigned on demand. The entire system is format-transparent making it suitable for a variety of applications and services. A bidirectional transmission of 10 Gb/s data rate per user using on-off-keying (OOK) modulation for downlink and 4QAM for uplink is demonstrated for proof-of-concept.

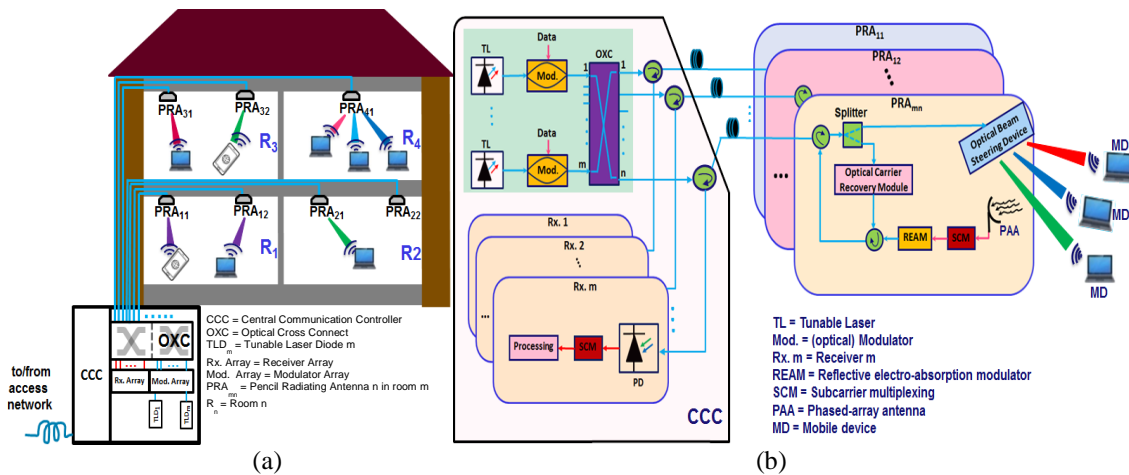

Fig. 1. (a) In-building fiber-wireless network architecture; (b) Network data plane employing optical wireless for downlink and subcarrier multiplexed RoF for uplink

## In-building network architecture

The proposed in-building network architecture is shown in Fig. 1(a). A central communication controller (CCC) terminates the access network and performs the in-building network management and control. It also hosts an optical-cross-connect (OXC) for dynamic signal routing to the appropriate rooms and device sharing. State-of-the-art switching technologies such as planar lightwave circuit (PLC) based thermo-optic switches, liquid crystals or micro-electro-mechanical-system (MEMS) based switches are considered for the OXC. The pencil radiating antennas (PRAs), fixed on the ceilings of the rooms, are connected to the OXC using single mode optical fibers. A room can be equipped with more than one PRA to ensure line-of-sight connections all the time. This concept supports more than one pico-cell per room which also means that the entire capacity is reusable even in a room. Hence, the wireless capacity, which can be very high, can be delivered according to the demand per user or per room. This makes the proposed concept future-proof. As a converged network, the system is completely transparent to modulation formats and data types, thus supporting a multitude of independently tailored services to users. A single fiber can be used for both uplink and downlink communication. Hence, installation becomes much simpler and manageable for home/building owners.

The downlink communication is purely optical, both along the wired part and the wireless part (pencil beam). The PRAs are passive devices used to steer pencil beams to intended users according to the wavelength of the incoming optical signal (may be more than one) from the wired network. Figure 1(b) shows the data plane of the proposed in-building network architecture. The downlink data streams modulate tunable laser sources (to support user mobility as the beam steering is wavelength based) using external optical modulators, and are then dynamically routed to the intended rooms by the OXC. Wavelengths in the C/L band (1500 nm – 1600 nm) are used as optical carriers. The PRAs in each room then steer the incoming signals to the specific users to which the data were sent using a passive diffractive element (e.g. 2D grating [5]). The beam steering is controlled by the wavelength of the incoming signal which is determined by the CCC using mm-wave tracking and localization methods.

In the uplink, 60 GHz range mm-wave radio signals are used for the wireless part. Using radio signals for uplink enables to implement reliable user tracking and localization for the downlink optical wireless communication. This allows to support user mobility in and between rooms and connection re-establishment in case of shadowing. A multi-beam phased-array antenna (PAA) can be employed to support multiple users simultaneously. At the PRA, since each user utilizes a 7-GHz bandwidth channel, the received mm-wave signals can be down-converted to different intermediate frequencies (IF) and can then be combined to form a single modulating data for the optical return path. The subcarrier multiplexing (SCM) module (see Fig. 1(b)) is responsible for this. The corresponding SCM module at the CCC demultiplexes the SCM signal which is further processed by other modules at the receiver. Reuse of the downlink wavelengths is analyzed as optical carriers for the uplink. This requires erasing the modulation from the downlink data instead of providing additional light sources making it more cost-efficient, by saving half the required number of light sources in the CCC. As illustrated in Fig. 1(b) the downlink data, upon arrival at the PRA, is split using an optical coupler: one branch going to the optical beam steering module for downlink routing, and the other branch to the optical carrier recovery module that erases the downlink modulation from the optical carrier. The recovered carrier is then modulated by the SCM signal using an intensity modulator.

### Simulation and Results

A proof-of-concept simulation verifying the subcarrier multiplexing and carrier reusing was carried out using VPI TransmissionMaker™ simulator. The simulation setup is shown in Fig. 2. At the CCC, a continuous wave laser source at 1550 nm wavelength and 3 dBm power is modulated by a 10 Gb/s on-off-keying (OOK) data with 10 dB extinction-ratio using a 10 GHz external intensity modulator, and launched to a 1 km single mode fiber after it was amplified to 0 dBm power. At the PRA, the received optical signal was first split by a 20:80 optical splitter (the 20% to the downlink receiver and the 80% to a saturated semiconductor optical amplifier (SOA) for carrier recovery). While the downlink signal was received by a low speed receiver that includes a photodiode and low-pass filter, the intensity of the recovered carrier was modulated by the SCM signal (consisting of four radio signals at frequencies of 6 GHz, 12.5 GHz, 19 GHz and 25.5 GHz) for transmission in the uplink using an external optical modulator of bandwidth 30 GHz. 4QAM modulation with symbol rate of 5 Gbaud was used for the individual radio signals. The uplink optical signal was launched to the 1 km optical fiber with 0 dBm optical power, and received and processed at the CCC as shown in Fig. 2.

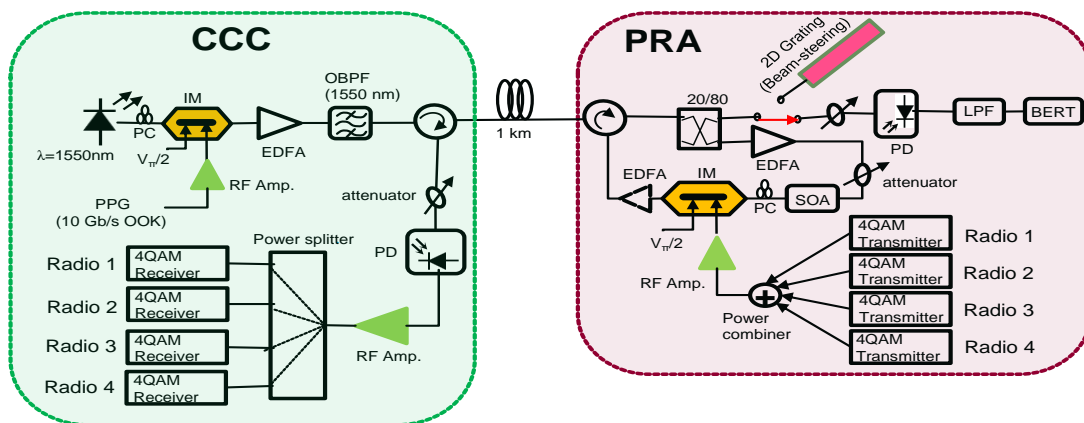

Fig. 2 Simulation setup

Fig. 3(a) shows the BER curve of the downlink data. The sensitivity was measured to be  $-21.5$  dBm. The RF spectrum at the receiver and error-vector-magnitude (EVM) performance of all the four radio signals, when the input power to the saturated SOA biased at 450 mA was 0 dBm, are shown in Fig. 3(b) and Fig. 3(c), respectively. The saturated SOA was able to erase the downlink modulation to  $<1$  dB. It can be seen that the effect of the residual downlink modulation on the uplink transmission is minimal allowing a single optical carrier to be used for both uplink and downlink communication without significant degradation.

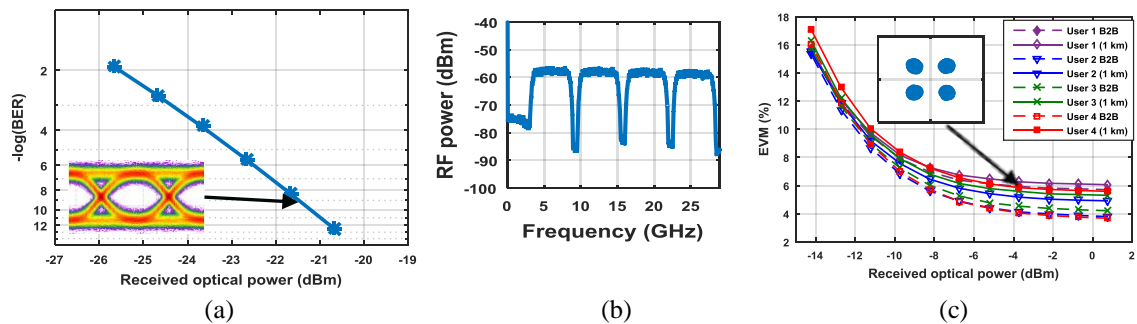

Fig. 3. Simulation results: (a) downlink BER (inset: eye diagram); (b) RF spectrum of the SCM radio signal at the receiver; (c) EVM of the four radio signals (inset: constellation)

## Conclusion

A hybrid and future-proof in-building backbone network architecture has been discussed for dynamic indoor wireless communication. The proposed architecture enables to benefit from the best aspects of optical and advanced radio communication systems, and since it is format and data type transparent, various services can be provisioned to users independently. The dynamic routing allows to deploy resources on demand saving energy and cost. A proof-of-concept bidirectional transmission of 10 Gb/s was demonstrated using OOK modulation for downlink and 4QAM for uplink.

## Acknowledgment

This work is funded by the European Research Council as part of the BROWSE project.

## References

- [1] "Cisco Visual Networking Index: Global Mobile Data Traffic Forecast Update, 2014–2019," Cisco Systems, San Jose, CA, USA.
- [2] K. Wang, A. Nirmalathas, C. Lim, and E. Skafidas., "High-speed indoor optical wireless communication system with single channel imaging receiver," *Optics Express*, vol. 20, no. 8, pp. 8442 - 8456, 2012.
- [3] J. K. Doyle, M. J. R. Heck, J. T. Bovington, J. D. Peters, L. A. Coldren, and J. E. Bowers, "Two-dimensional free-space beam steering with an optical phased array on silicon-on-insulator," *Optics Express*, vol. 19, no. 22, pp. 21595 – 21604, 2011.
- [4] P. Brandl, S. Schidl, A. Polzer, W. Gaberl, and H. Zimmermann, "Optical wireless communication with adaptive focus and MEMS-based beam steering," *IEEE Photonic Technology Letters*, vol. 25, no. 15, pp. 1428 – 1431, 2013.
- [5] A.M.J. Koonen, C.W. Oh, E. Tangdiongga, "Reconfigurable free-space optical indoor network using multiple pencil beam steering," in Proc. OECC, Melbourne, Australia, pp.204-206, Jul. 6 – 10, 2014.
- [6] T. Gigl, G. J. M. Janssen, V. Dizdarevic, K. Witrisal, and Z. Irahauten, "Analysis of a UWB indoor positioning system based on received signal strength," 4th Workshop on Positioning, Navigation and Communication, pp. 97 – 101, Hannover, Germany, 2007.